

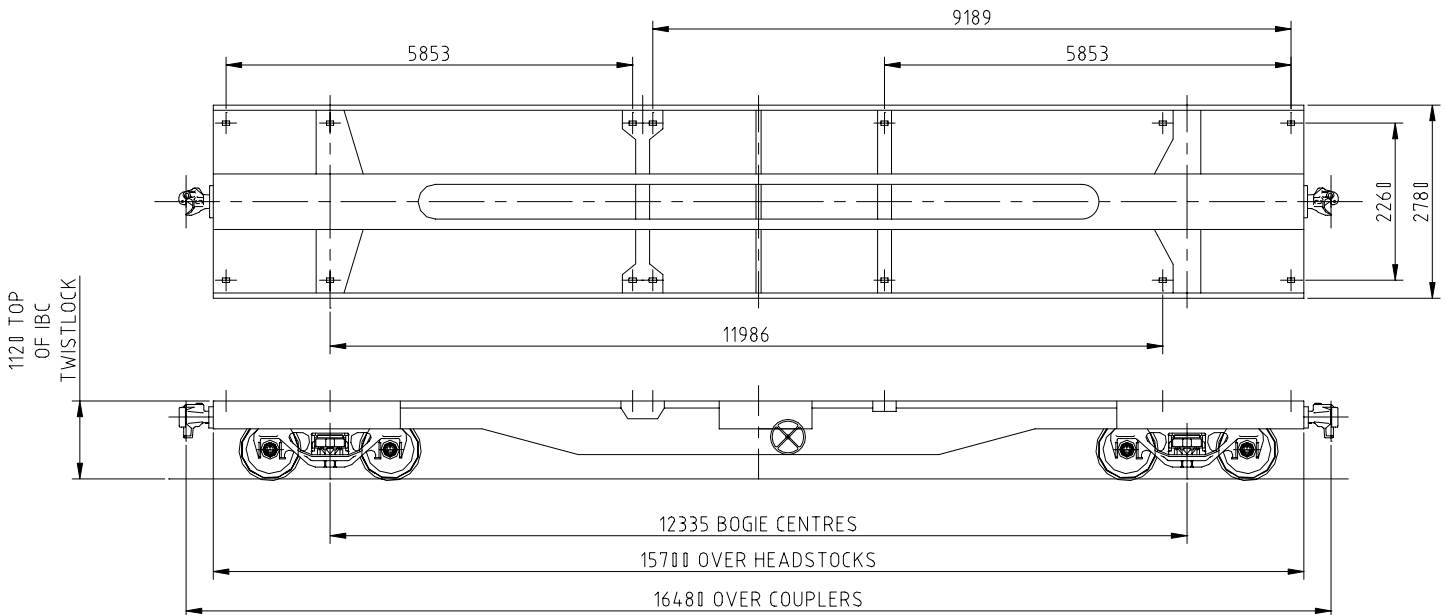

Class	CQHY	Tare Weight	18.3 tonnes
Wagon Type	Container	Gross Mass	84.0 tonnes
Twistlocks	2x20ft, 1x30ft, 1x40/48ft	Capacity	65.7 tonnes
Previous Class	NDRF	Unit Length	16.5 m
Number in Class	8	Maximum Speed	100 km/h
Wagon Numbers	056-063	Deck Height	1120 mm
Rebuild Date	2001-02	Draw Capacity	1.80 Mn
Rollingstock Outline	ROA Plate C	RIC Class	B





Wagon Class

CQHY

Loading Specifications

Designer

Central Design P. Dixon &
WR Edmonds

Builder

RSA - Goulburn

Rebuild Date

2001-02

GA Drawing No.

RSA 01101

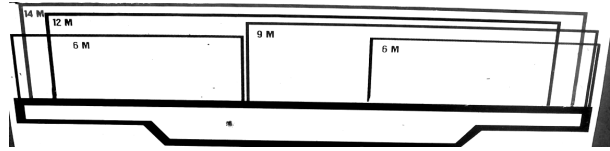

Bogie Details

Bogie Type	70t Ride Control
Designation	AAR Class 2E
Axle Load	25 Tonne
Load Springs	AAR D5 x 7 Outer AAR D5 x 3 Inner
F. Wedge Springs	RFE 18 x 1 Outer
Wheel Diameter	840mm
Journal Centres	1981mm
Wheelbase	1727mm
Centre Plate	Welded 350mm
Journal Bearings	6"x11"
Brake Lever Ratio	4:1
Side Bearers	Stucki ISB-2LP

Brake Details

Assembly Drawing	N/A
Brake Cylinder Type	2x254mm dia. WHB #C4784
Mounting	Body
Relay Valve	N/A
Triple Valve	WF3-14 Recon. WHB #C18144
Load Compensation	Manual WHB #C8010
Grade Control	Choked
Slack Adjuster	None
Hand Brake	Transverse
Bifurcated Pipe	No

Draftgear

Assembly Drawing	N/A
Draftgear Spec	AAR M-901 E
Coupler Type	BK16752
Coupler Length	680mm

Twistlocks

Twistlock Type	Manual or Auto
Total No.	8